

**DM52A2/L163A1**  
**Electronic Time**  
**Artillery Fuze**



for artillery smoke and illuminating projectiles

## DM52A2/L163A1

The DM52A2 is an inductively settable electronic time fuze for artillery. It has been designed for use with 105 mm and 155 mm carrier shells and is suitable for use with all weapon systems including 52 calibres, fitted with the latest generation of flick-ramming systems. This fuze is qualified for use with smoke and illuminating ammunition, as well as sensor fuzed munitions, for example SMArt® 155 mm. The latest variant of the DM52A2 fuze is now in service as L163A1.

The DM52A2 is derived from the well proven and successful DM52A1 fuze design, of which more than 200,000 have been produced for the German Armed Forces (for use in PzH 2000), and also for a number of other nations.

The fuze time is set inductively from 2 to 199.9 seconds (in 0.1 second increments), either during automatic loading or by means of a fuze setting device designed in accordance with STANAG 4369 and AOP 22. The fuze setting is stored permanently but can be reprogrammed at any time prior to firing. An impact function is available as an option.

The fuze complies with STANAG 4187 and provides safety distances of 150 m for 105 mm and 200 m for 155 mm weapon systems.

In addition, the fuze affords a high level of in-flight safety, as the ignition capacitor is only charged 2 seconds before the designated time of function.

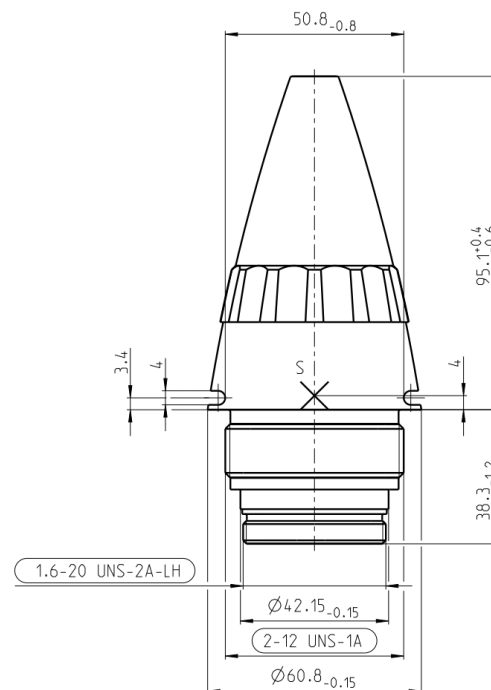

### Technical Data DM52A2/L163A1

Muzzle safety	> 200 m (155 mm)
El. overhead safety	T* -2 sec. T* = programmed Time of Flight
Required setback for arming	≥ 1,000 g
Max. setback	< 26,000 g
Required rotation for arming	≥ 2,900 rpm
Max. rotation	< 25,000 rpm
Storage temperature range	-54°C to +71°C
Operational temperature range	-46°C to +63°C
Dimensions	STANAG 2916
Weight	420 ± 20 g
Shelf life	10 years
Compliance with MIL-STD 1316C / STANAG 4187, MIL-STD 331B / STANAG 4157, STANAG 4369	

JUNGHANS Microtec GmbH  
 Unterbergenweg 10  
 78655 Dunningen-Seedorf  
 Germany  
 Phone +49 7402 181-0  
 Fax +49 7402 181-400

JUNGHANS T2M SAS  
 Route d'Ardon  
 45240 La Ferté Saint Aubin  
 France  
 Phone +33 2 3851-6422  
 Fax +33 2 3851-6835

www.junghans-defence.com  
 info@junghans-defence.com

A Diehl and Thales company